

# AX'B

INSTALLATION, OPERATION AND MAINTENANCE INSTRUCTIONS





## SOMMAIRE

1 -	RECEIPT OF THE UNIT.....	2
1.1	Delivery/Reservations.....	2
1.2	Storage precautions.....	2
1.3	Packaging .....	2
1.4	Handling.....	2
2 -	SAFETY INSTRUCTIONS.....	2
2.1	1 General safety instructions .....	2
2.2	Field of application.....	2
3 -	DESCRIPTION OF THE UNIT .....	3
3.1	Fixed name plate .....	3
3.2	Pictograms.....	3
4 -	INSTALLATION AND CONNECTIONS INSTALLATION .....	4
4.1	Selecting a location .....	4
4.2	Mounting .....	4
4.3	Air connection .....	7
4.4	Hydraulic connections.....	7
4.5	Servomotors .....	8
4.6	Electrical connections.....	8
4.6.1	Fan motor assembly:.....	8
4.6.2	Electric heater: .....	10
5 -	SYSTEM START-UP .....	12
6 -	MAINTENANCE/SERVICE INTERVALS.....	14
7 -	REGULATION .....	14

**Warning:** this document is provided for information only, subject to possible evolutions. HYDRONIC will not be held responsible for any errors or omissions that may exist in the contents of this leaflet.



For your safety, consider equipping yourself with different EPI

The installation and maintenance operations must be performed by qualified and experienced personnel. Follow the operating precautions to the letter when working on the unit. Labels have been placed on the unit to remind you of the safety instructions.

This appliance is not designed to be used by persons (including children) with limited physical, sensory or mental capabilities, or by persons with insufficient experience or knowledge, unless they are being supervised by a person responsible for their safety or have received instructions on the use of the appliance from such a person.

Children must be supervised to ensure that they do not play on or with the appliance.

As a general rule, follow all applicable safety regulations and standards.

Damage to the dual-flow air handling unit will be disregarded in the event of failure to follow the instructions in this document.

## **1 - RECEIPT OF THE UNIT**

Each unit has a nameplate with an identification number, to be mentioned in all correspondence.

### **1.1 Delivery/Reservations**

In accordance with Article 133-3 of the French Code of Commerce, the recipient is entirely responsible for checking the condition of the goods received. In the event of missing items, the customer must provide the exact number of parcels delivered. Any damaged or missing items must be specified on the delivery note in the presence of the driver before signing the delivery note. These comments must be confirmed to the carrier by registered letter within two business days, and a copy of this letter must be sent to the manufacturer. The comments "conditional" and "pending unwrapping" shall have no value. The client must unwrap the goods in the presence of the driver. Claims must be made at the time of delivery and be described in detail.

### **1.2 Storage precautions**

If the unit is not to be installed immediately, it must be protected from the elements; storage in the packaging is recommended.

### **1.3 Packaging**

The unit is packed on a pallet covered by shrink wrap film. Any additional casings may be packed on the same pallet, under the same film.

### **1.4 Handling**

The entire pallet and contents must be handled with care using a forklift truck or manual stacker.

## **2 - SAFETY INSTRUCTIONS**

### **2.1 1 General safety instructions**

- The following must be performed before any work on the air handling unit:
- The power must be switched off (proximity switch)
- Electrical equipment must be switched off (electric heater with fan delay, humidifier, etc.)
- The fan must be stopped (WARNING: it may take several minutes to stop completely)
- Work must be carried out by an accredited technician.

### **2.2 Field of application**

AX'B can only be used in the application AIR TREATMENT.

AHU Outside : -20°C / + 40°C (out of water)

AHU Inside : -25°C / + 60°C MAXI

Cold fluid: fluid inlet temperature > 5°C

Hot fluid: the characteristics are mentioned on the manufacturer's nameplate (temperature and pressure)





**Comply with the type of fluid given on the name plate**

### 3 - DESCRIPTION OF THE UNIT

#### 3.1 Fixed name plate

This is fixed on the unit and shows the unit's specifications as well as the order number and code.

N°série / Serial No.	
Type / Type	
Moteur / Motor	
Electrique / Electrical	
Fluide / Fluid	
Année de construction / Date of Manufacture	
	HYDRONIC SAS 61400 MORTAGNE AU PERCHE - FRANCE TEL: 02 33 85 14 00 www.hydronic.com
	

#### 3.2 Pictograms

Connection side (right-hand orientation)

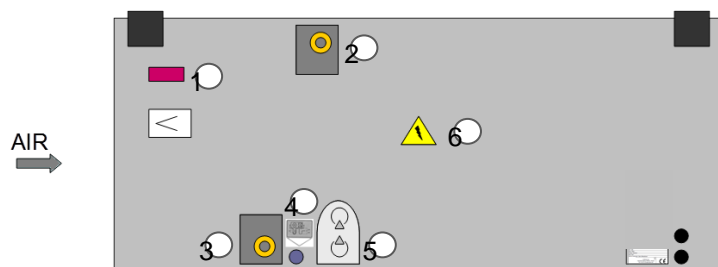

1 - Filter safety device

2 - Fluid inlet

3 - Fluid outlet

4 - Condensate outlet pictogram

5 - Fluid direction pictogram

6 - Electrical safety device

7 - Name plate

## 4 - INSTALLATION AND CONNECTIONS



The installation of the equipment must comply with the regulations and standards of the recipient country.

### 4.1 Selecting a location

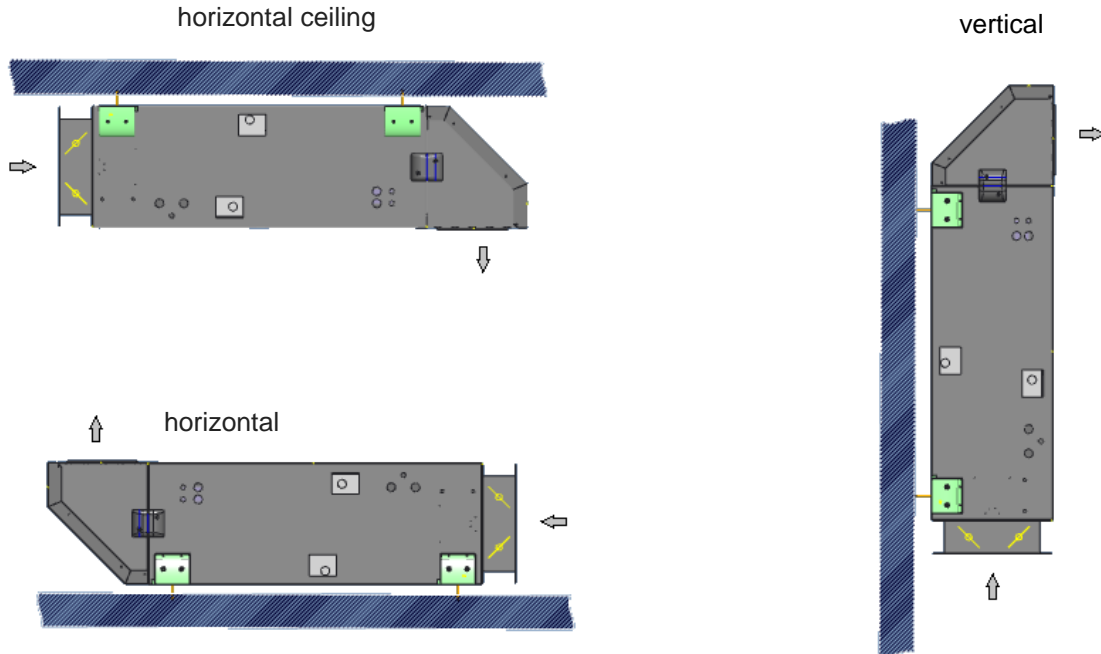

Depending on the type of unit being controlled, it can either be ceiling- or floor-mounted or installed vertically.

Ensure a minimum space is left to allow the doors to open (540mm, 595mm, 735mm depending on the configuration). However, if this access cannot be provided, all of the doors can be removed from their hinges to gain access.

Details of hinges/handles: Allen key lock, size 4

When they are unlocked, the handles are in "hinge" mode. It is possible to unlock a single row of handles to open like a conventional door. If all of the handles are unlocked, the door can be removed.

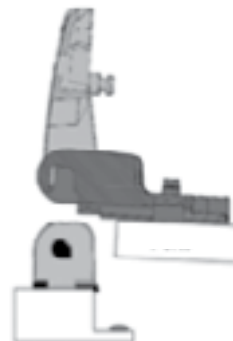
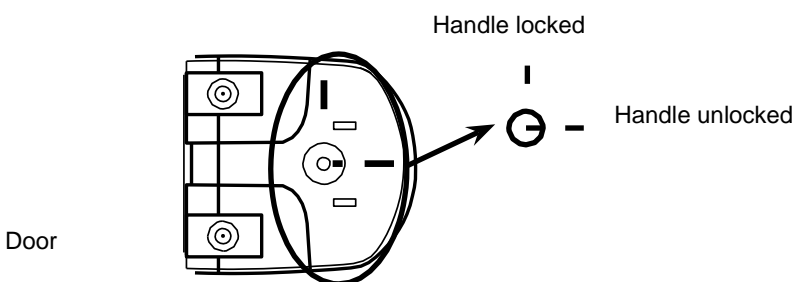

### 4.2 Mounting

For ceiling-mounted units, two solutions are possible depending on your lifting equipment:

- Secure the main casing to the ceiling, then assemble the additional casings and secure these to the ceiling.
- Assemble the main casing and the additional casings on the floor, then raise the assembly and secure it to the ceiling.

Mounting to their support:

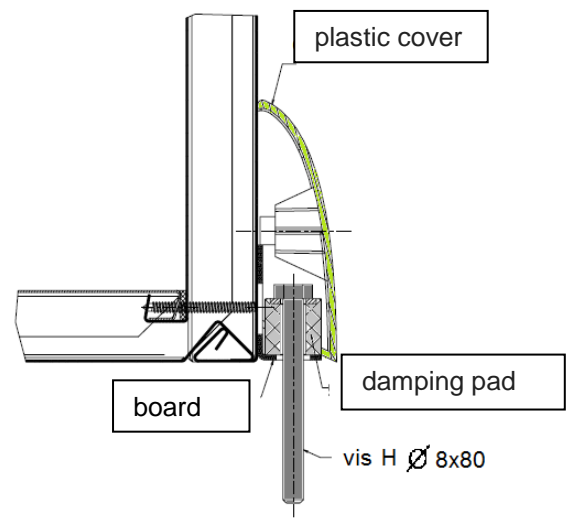
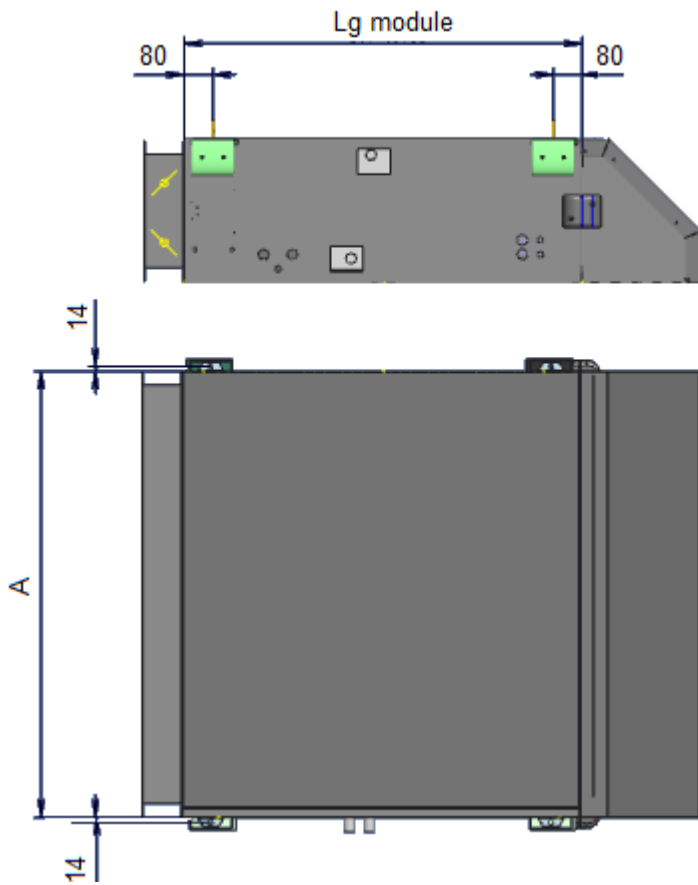

Assembling the casings (for multi-unit AHUs):

- Bond the PVC 25x5 gasket to the connection face of the additional casing
- Fit the threaded rods in the plates
- Secure the additional casing to the main casing using the nuts provided (the casings must be perfectly aligned to ensure the tightness of the assembly)

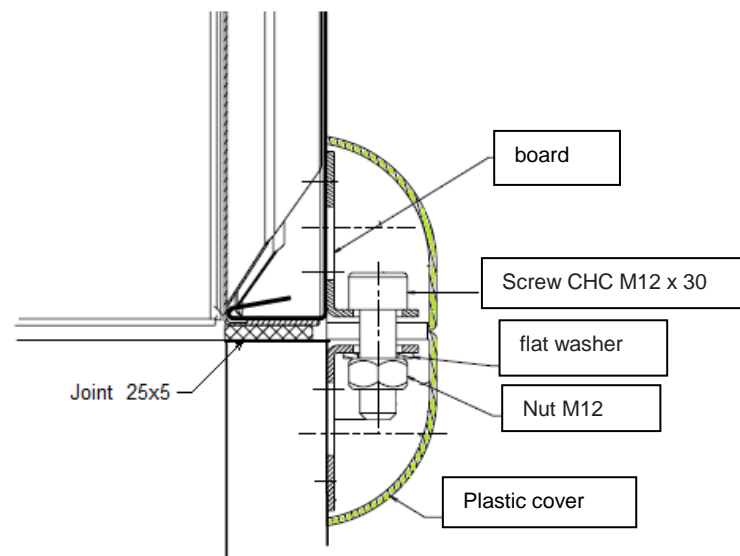
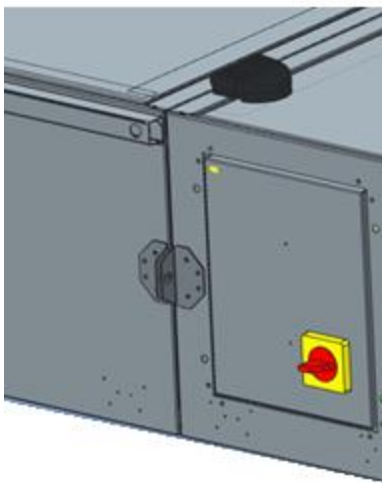

Assembly between caissons and plate recuperator block HEE :

- Glue the 25x5 PVC seal on the connecting face of the additional boxes.
- Place the threaded rods in the room inside the recuperator to enter the tension nuts.

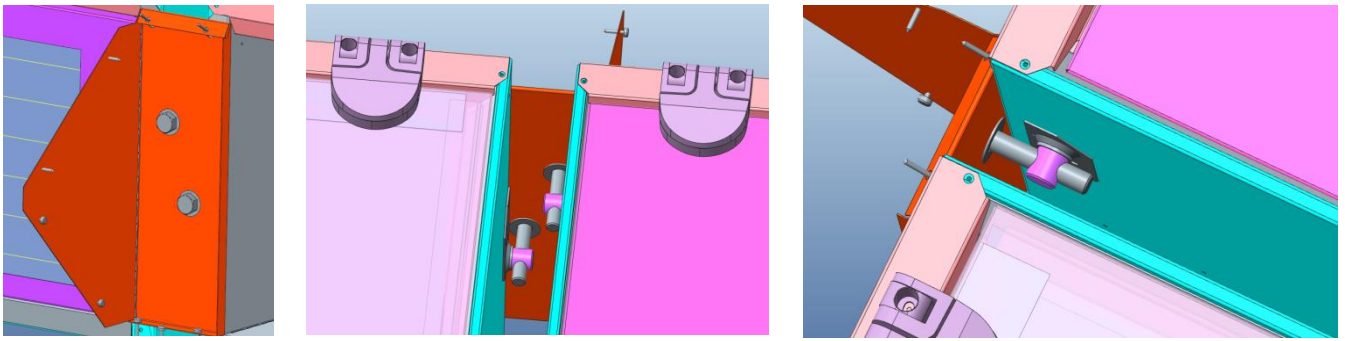

- The boxes must be perfectly aligned to ensure the tightness of the assembly)

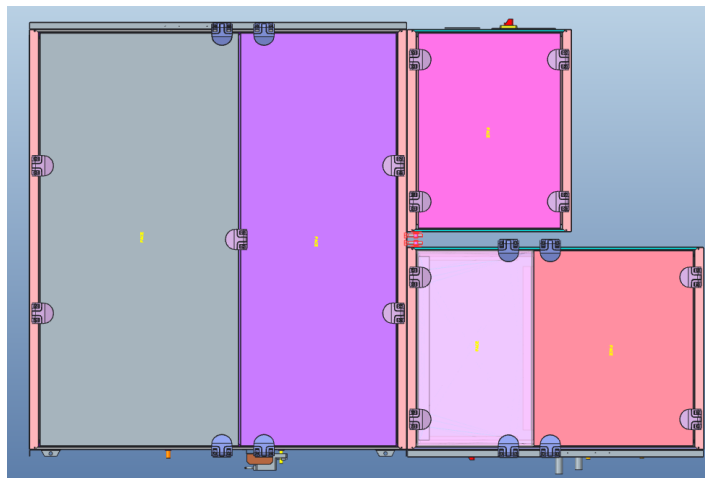

- Tighten the additional boxes on the recuperator block.

Necessary accessories

- 2 screws H M12x60
- 2 flat washers M12 U
- 2 tensions nuts M12
- 2 connection boards



### 4.3 Air connection

Connections must not place mechanical stresses on the unit  
Use the flexible sleeves for the intake and discharge.

**Intake or discharge :**

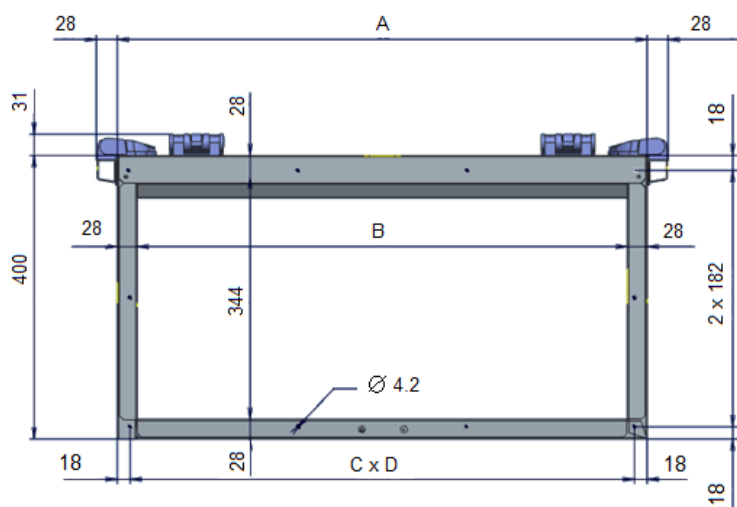

sizes	A	B	C	D
25	750	694	3	238
40	1310	1254	6	212.3
60	1880	1824	8	230.5

2 ways

3 ways

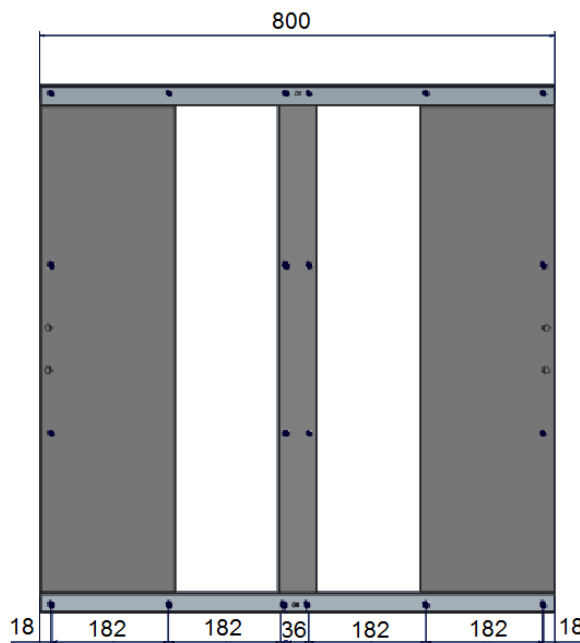
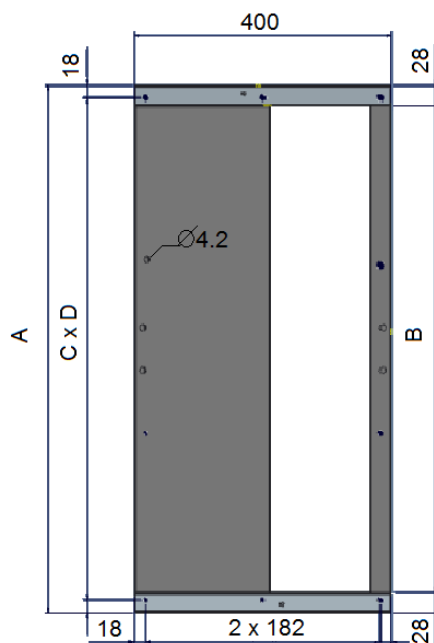

### 4.4 Hydraulic connections

Ensure the hydraulic connections are fitted in the correct direction  
Check that the condensate water will drain correctly



**The manufacturer cannot be held liable if the coil is damaged by freezing water.**

Schematic diagram of the siphon

For a depression H in the cooling coil, the sizing of the siphon must incorporate dimensions of 2H.

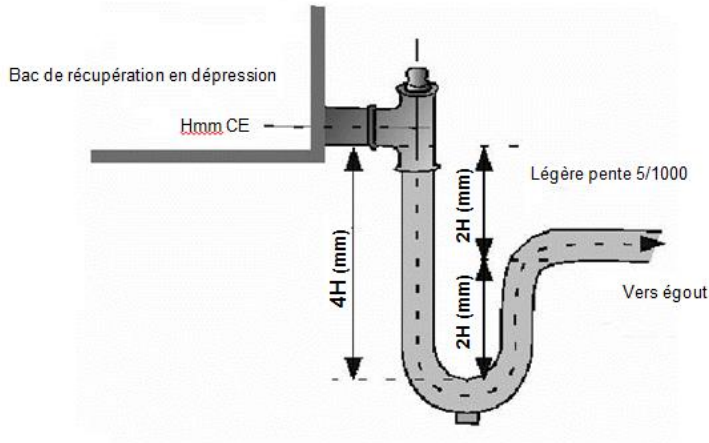

#### 4.5 Servomotors

Closing torque for the dampers:

	25	40	60
Intake damper *	4	4	10
2 ways mixing box	5	5	5
3 ways mixing box	5	10	10
Plate heat exchanger bypass	5	5	

\* With spring-return

#### 4.6 Electrical connections

##### 4.6.1 Fan motor assembly:

Plug fan with asynchronous motor:

- Motor electrical connection
- Connection to the motor terminal boxes, according to the various current standards

Motor r	Nominal current IN (230V / □)	Nominal current IN (400V / Y)
0.55kw / 4 pole	2.4*	1.4*
1.1kw / 2 pole	4.2*	2.4*
1.4kw / 2 pole	5.0*	2.9*

\* Per motor

Fan motor assembly and frequency inverter combinations

Refer to the manufacturer's manual for wiring, settings and commissioning.

Inverter parameter list Unidrive M100 (manufacturer supply)

The usual diagnostic parameters are:

01.001 Frequency Reference  
 04.001 Engine total current  
 04.002 Motor Active Current  
 04.017 Magnetic current  
 05.001 Frequency of exit  
 05.002 Output voltage  
 05.003 Power  
 05.004 Engine speed  
 05.005 DC bus voltage  
 07.001 Analog input

The values in bold are the values to be modified compared to the factory settings

Para.	Description	Factory setting	Setting 1: Speed by potentiometer	Setting 2: Speed per contact	Setting 3: Keyboard Speed
		Eur			
00.001	Minimum speed (Hz)	0	20		
00.002	Maximum speed (Hz)	50	Motor 0,55kW : <b>97</b> ; Motor 1.1kW : <b>60</b> ; Motor 1.4kW : <b>65</b>		
00.003	Acceleration ramp (s/100Hz)	5	5		
00.004	Deceleration ramp (s/100Hz)	10	10		
00.005	Configuring the inverter	AV (0)	AV (0)	Preset (4)	Pad (5)
00.006	Rated motor current (A)	Surcharge maximum / Maximum Heavy Duty Rating	230V / Δ : 1 motor : 0,55kW : <b>2.4</b> ; 1.1kW : <b>4.2</b> ; 1.4kW : <b>5</b> 2 motors : 0,55kW : <b>4.8</b> ; 1.1kW : <b>8.4</b> ; 1.4kW : <b>10</b> 400V / Y : 1 motor : 0,55kW : <b>1.4</b> ; 1.1kW : <b>2.4</b> ; 1.4kW : <b>2.9</b> 2 motors : 0,55kW : <b>2.8</b> ; 1.1kW : <b>4.8</b> ; 1.4kW : <b>5.8</b>		
00.007	Motor rated speed (min <sup>-1</sup> )	1500	Motor 0,55kW : <b>1390</b> ; Motor 1.1kW : <b>2880</b> ; Motor 1.4kW : <b>2839</b>		
00.008	Rated motor voltage (V)	230/400	230/400	230/400	230/400
00.009	Engine power factor (cosφ)	0.85	Motor 0,55kW : <b>0.8</b> ; Motor 1.1kW : <b>0.81</b> ; Motor 1.4kW : <b>0.88</b>		
00.010	Access to parameters	LEVEL.0 (0)	ALL (1)		
Level settings « ALL »					
00.016	Analog input mode 1	Volt (6)	Volt (6)		
00.018	Preset speed 1 (Hz)	0		speed 1	
01.022	Preset speed 2 (Hz)	0		speed 2	
01.023	Preset speed 3 (Hz)	0		speed 3	
01.024	Preset speed 4 (Hz)	0		speed 4	
00.025	User security code	0	4-digit code (if needed)		
00.027	Power On Keyboard Reference	Reset (0)	Reset (0)	Reset (0)	Last (1)
00.031	Mode d'arrêt / Stop mode	rP (1)	CoASt (0)		
00.032	Sélection U/f dynamique	0	1		
00.033	Resumption on the fly	dis (0)	Fr.OnLy (2)		
00.037	Maximum switching frequency (kHz)	3 (3)	A adjust if necessary		
00.041	Control mode	Ur.I (4)	Ur_Auto (3)		
00.077	Maximum rated current at maximum overload (A)	-	Rated motor current +10% (A)		

**GMV with EC motor :**

As standard, EC motors are supplied with connectors which allow them to be connected to the terminal box with no intervention. Two cables (power and control) are provided to facilitate connection to the connectors

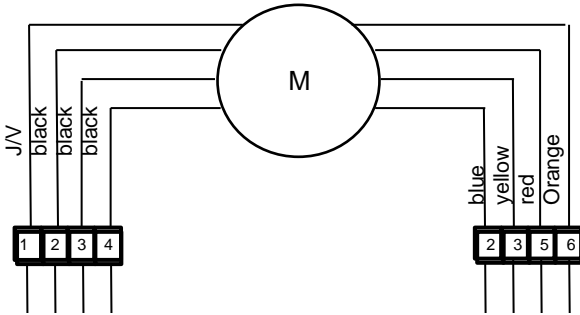

Power cable		Control cable	
4	Phase L1	6	Potential free, normally closed state signalling contact
3	Phase L2	5	Potential free state signalling contact, changeover switch, shared connection (2A, max 250 VCA, min.10mA, AC1)
2	Phase L3	3	0-10 VDC actual value/control input, impedance 100kOhm; only use as an alternative to the 4-20mA input, SELV
1	Earth	2	0-10 VDC actual value/control input, impedance 100kOhm; only use as an alternative to the 4-20mA input, SELV

**4.6.2 Electric heater:**

**Without box:**

- Connection to the coil terminals (accessible from the side).

With regard to the heaters

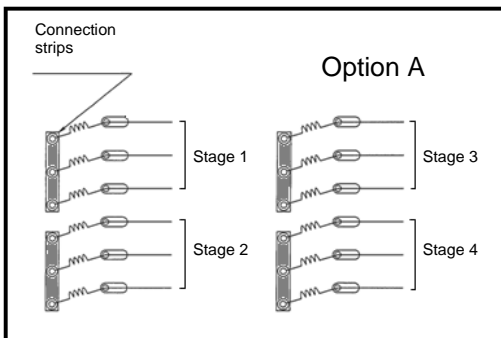

At the terminal block

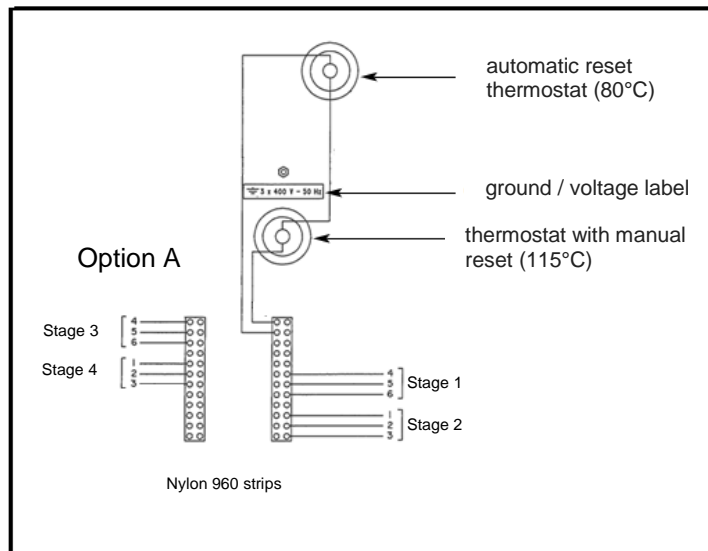

	Power (kW)	Number of stages	Power (kW)	Number of stages
			Option A	
size 25	15	2	30	4
size 40	24	2	48	4
size 60	33	2	66	4

**With electric box: On/Off or TRIAC:**

Box not available for option A.

Box options:

- o Option B: On/Off (2 stages) / fitted and wired
- o Option C: On/Off (2 stages) / box not fitted and not wired
- o Option D: modulating with TRIAC (1 On/Off stage + 1 modulating stage)
- o Option E: modulating with TRIAC (1 On/Off stage + 1 modulating stage) / box not fitted and not wired

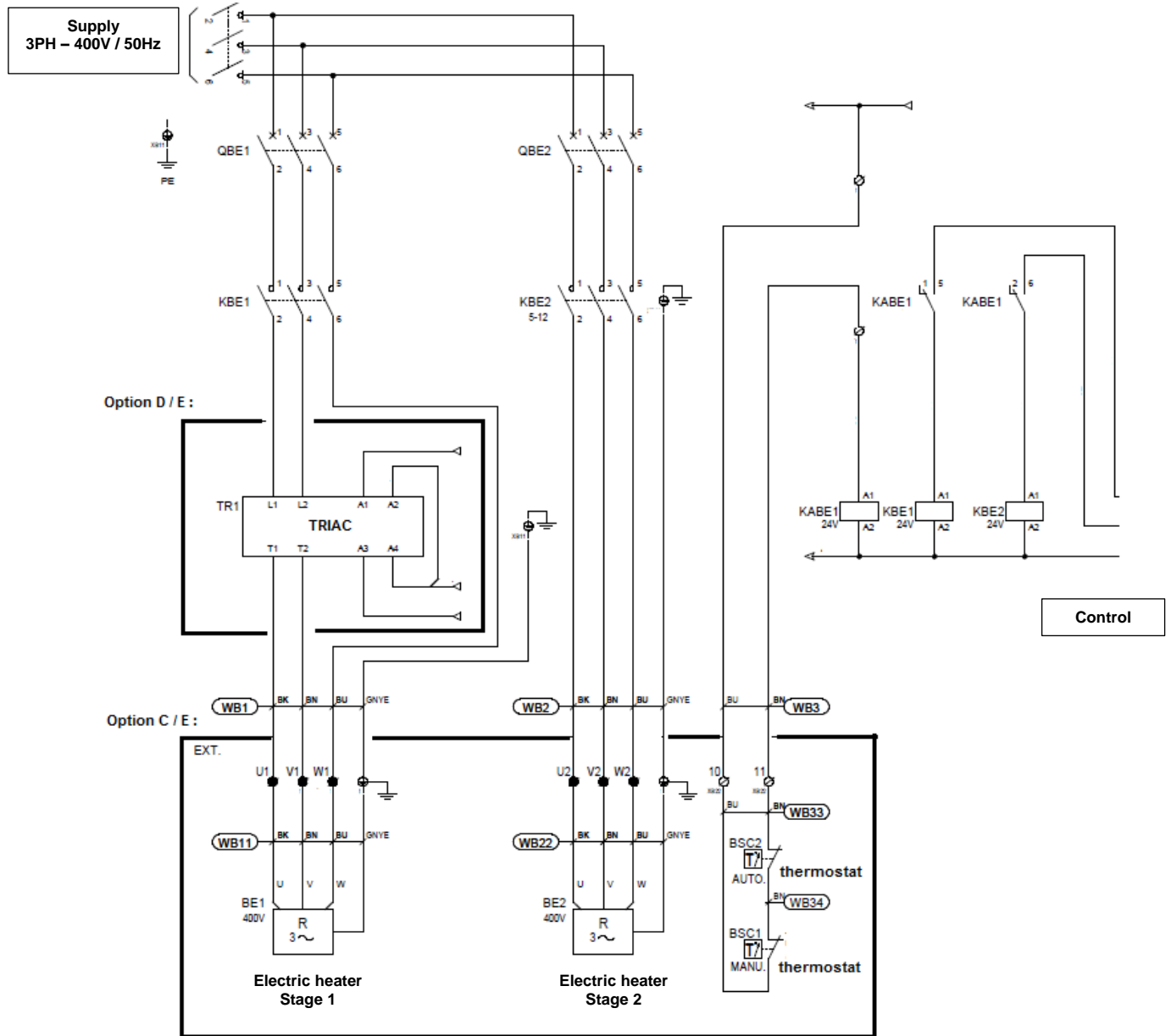

To be wired:

- 3-PH – 400V supply
- Control/protection
- Option C and E: to be wired between the electric box and the heater terminal. Cable to be supplied at the customer's expense (See 4.6.2: without box).



**The activation of the electric heater stages or the output modulation must be slaved to the AHU's air flow. A fan delay must be provided as part of the control tender.**

## 5 - SYSTEM START-UP



**System start-up must be performed by qualified personnel, trained in air handling technology. Keep all inspection doors closed while the unit is operating.**

Once the electrical, hydraulic and air connections are complete, system start-up can be performed on the unit, checking the points below:

- The tightening of the connections between the casings.
- The mounting to its support.
- The level of cleanliness inside the unit and the hydraulic network; there must be no foreign bodies inside either. If necessary, clean the panels using a spray and a washing solution and dry with a soft cloth.
- The safety setpoint on the supply air temperature must be  $< 60^{\circ}\text{C}$
- The pressure switch rating must be compatible with the theoretical operating pressure.

### **Mixing boxes/dampers:**

- Check the operation and condition of the movable components. For fixed settings, check that they remain in the selected open position.

### **Filters:**

- Check that these are present and clean.
- Connect a pressure gauge or pressure switch (depending on selection) to the pressure connections and check the filter pressure drops. If the filter is fitted in the casing connecting frame (option: CFA, CFR and double filtration in the main casing), one of the pressure connections is fitted on the casing and the second is supplied in kit form (to be fitted on the duct).
- Start the installation with the prefilters only. After a few hours, change them if necessary and install all the filter stages.

### **Plate heat exchangers:**

- Check that the siphon is present on the condensate drain, that it is correctly sized and that there are no foreign bodies liable to obstruct drainage
- Check that the siphon can be primed
- Check that the bypass damper operates correctly

### **Hydraulic coils:**

- Check the condition of the connections (tightness, operating pressure, draining at the high points)
- Check the position of the droplet eliminator (cooling coils)
- Check that the siphon is present on the condensate drain, that it is correctly sized and that there are no foreign bodies liable to obstruct drainage (cooling coils)
- Check that the siphon can be primed

### **Direct expansion coil**

- For coils containing "SPLIT SYSTEM" refrigerant, the unit must not be stored near to a source of heat or in direct sunlight (increase in refrigerant pressure).

### **Electric heaters:**

- Check the presence and mounting of the terminal block protection plate.
- Check the connection of the safety devices:
  - Manual-reset thermostat (cut-out at  $115^{\circ}\text{C}$ )
  - Automatic-reset thermostat (cut-out at  $80^{\circ}\text{C}$ )

Resets may only be carried out after the installation is checked and the causes of the activation identified.

- Compulsory slaving to the air flow; no start-up without air flow, and stop if excess air flow: risk of fire
- Check that the heater (total or partial) can only operate in the presence of ventilation, by using an air flow detector.
- The ventilation must only stop once the electric heater has been stopped for a few minutes: ensure a time delay of 5 to 10 minutes to allow the heat to dissipate
- Check that the heater's output is proportional to the air flow, if there is a variable flow rate
- Check that the minimum air speed is 2m/s in the operating phase
- Check the connection to earth).

**Fan motor assemblies:**

- Check the power supply voltage and heat protection calibration in accordance with the current ratings of the various elements
- Check that the earth is connected and that the wheel turns freely
- Check the air flow and operating pressure

**Calculating the air flow:**

Plug fan with asynchronous motor:	Plug fan with EC motor:
$Q = K \sqrt{\frac{2}{\rho} \cdot (\Delta p)} \times \text{Nombre de GMV}$ <p>Q: air flow (m<sup>3</sup>/h)            ρ: air volume mass (kg/m<sup>3</sup>) P: pressure (Pa)            K = 60 (for NPL 280 FMA)</p>	$Q = K \sqrt{(\Delta p)} \times \text{Nombre de GMV}$ <p>Q: air flow (m<sup>3</sup>/h)            ρ: air volume mass (kg/m<sup>3</sup>) P: pressure (Pa)            K = 93 (for K3G 280 FMA)</p>

## 6 - MAINTENANCE/SERVICE INTERVALS



Switch off the power supply to the air handling unit before carrying out any work

Maintenance must be performed by qualified personnel

Stop the machine via the human-machine interface then switch off the power supply (fan delay times must be complied with)

It is possible to remove the doors in order to facilitate access to the various components thanks to the detachable hinges. For all models: open the latches using the wrench provided.

Regular maintenance will keep the unit running at optimum performance levels. The values given in the table below are provided for guidance only. They do not take into account individual factors that can lengthen or shorten the unit's service life

Component	Required	Recommendation
Tunnel	Check the cleanliness	6 months
	Check for corrosion	6 months
Mixing boxes and dampers	Check that the servomotors operate correctly	12 months
Filters	Check the fouling level (visual and pressure drop)	3 months
	Replace	Depending on operating conditions. Replace every 2 years, even for less intensive use Filter combination: remove the folded F7 or F9 filters firstly then remove the G4 prefilter
Plate heat exchangers	Remove dust/grease and carry out maintenance on the bypass damper	12 months
	Clean and degrease the condensate drain pan using water and non-abrasive detergents	12 months
Hydraulic coils	Check the cleanliness	6 months
	Check the level of antifreeze	Depending on operating conditions
	Drain the coil	Depending on operating conditions
	Check that the droplet eliminator is clean	12 months
Electric heaters	Visually inspect the heaters and connection cables	1500 hours
	Check and retighten the electrical connection	6 months
Fan motor assemblies	Check the impellers (visually)	6 months
	Check the various fixings (visually)	6 months
	Check the various connections	6 months
Sound attenuator	Check the cleanliness and condition (tears)	6 months

## 7 - REGULATION

Refer to the control manual.







CS30064 - F - 61400 MORTAGNE-AU-PERCHE  
Tél : 00 33 (0)2 33 85 14 00



31, rue de la Justice  
ZI de Vaux-le-Pénil - F - 77000 VAUX-LE-PENIL  
Tél. : 00 33 (0)1 64 87 78 77



This document is not legally binding.  
As part of our continuous drive to improve our products, HYDRONIC reserves the right to make any technical modifications without prior notice.